

Coaching Manual and Resources 2024



Welcome to New Westminister Little League!

Thank you so much for deciding to volunteer your time to coach with us here in New West. Our organization relies on parent and community volunteers to provide our kids with an opportunity to learn and play this great game. We have over 70 years of legacy and tradition of great baseball in the Royal City. We've put together this coaching manual to help connect you with our organization and the resources we have available to make for the best possible experience on field for you and your team.

★ **Our Mission Statement:** To provide a fun, fair and positive baseball environment to develop student athletes who are committed to achieving excellence in the classroom, on the field, and in our community while reaching out to the local community to encourage involvement through sponsorships and support.

★ **League Information:**

- We are a member organization of **Little League Canada** and play in the **District Six Region** of BC along with Trout Lake, Hastings Community and South Vancouver Little Leagues
- We offer baseball opportunities from 4 yrs to 18 yrs and all age ranges in between. Information on each level of baseball offered by New Westminister can be found on our website at: <https://www.newwestbaseball.com>

This manual is organized to give you all the pertinent league/sport information and resources for being a coach/manager in our organization. Please save and keep an electronic copy for reference throughout the season. We will attempt to keep all links and references as up to date and accurate as possible but reserve the right to make any changes. If you have questions and/or need to connect with someone on the Executive Board, please see the website link of current board members and their contact info: <https://www.newwestbaseball.com/board>

This coaches manual will also provide some clarification of key administrative knowledge & duties that might be required and the skills and team concepts that are expected to be taught, as well as, how they can be taught in very simplistic, easy to understand language. Along with guiding coaches on our approach for teaching the fundamentals of the game, the manual also provides some assistance on how to run an effective game / practice and

maximize the time you have with the team. It explains your role in creating a safe practice and game environment as well as some best practices for how to effectively communicate with your parents during the season.

- ★ Of note, We are returning to full play with no Covid restrictions. That said, it is expected that players, coaches, volunteers and spectators do not participate when they have a contagious illness. Please stay home when sick. Guidelines in this manual could be revised at any time to keep in line with the Government and Health Authority recommendations, as well as those recommendations provided by our Health Authority and Baseball BC.

COACHING DUTIES:

We want every team to have enough help and leadership. A Head Coach, at least one Assistant Coach and a 2nd Assistant/Team Manager should be selected before the start of the season. Parent participation is key in filling these roles.

The job descriptions are as follows:

- **Head Coach (T-Ball, Rookie) or Team Manager (Minor, Major, Junior, Senior):**
 - o In charge of developing practice plans, practice schedules, game lineups and strategies
 - o Primary contact with Division Coordinator
 - o Provides guidance to athletes on the fundamentals and being a member of a team
- **Assistant Coach:**
 - o Supports Head Coach's practice plans and game strategies.
 - o Accomplishes tasks of Head Coach when Head Coach is not available.
 - o Secondary contact with division coordinator
 - o Provides guidance to athletes on the fundamentals of baseball and being a member of a team
- **Team Parent and/or 2nd Assistant:**
 - o Assists Head Coach and Assistant Coach with daily activities of the team
 - o Primary contact with parents of players
 - o Primarily keeps control and organization of the dugout
 - o Helps tend to minor First Aid issues during practices and games *if no other designated first aid attendant
 - o Announces Lineup and keeps batting order prepared
 - o Is sometimes chosen to communicate changes in schedule
 - o Organizes parents and collects completed any Code of Conduct forms, Baseball BC waivers, photo releases, uniform tracking sheets

All parents are encouraged to manage, coach, or assistant coach, a team within our Association. In most cases, returning Team Managers, Head Coaches and Assistant Coaches are approached first, followed by a search of new candidates that expressed interest via their child's registration form. In rare cases, a Team Manager, Head Coach or Assistant Coach may be chosen even though they do not have any children in the program; paid coaching personnel could occur at the Major, Junior and Senior levels. This will be done after an interview process conducted by the NWBA board members.

CRIMINAL RECORD CHECKS (CRC)

In an effort to minimize potential risk to players and other team participants, NWBA requires all of their coaches, team managers, umpires and Executive Members to undergo a criminal record check (vulnerable sector) every three years. Any CRC that is older than July 2019 will need to be re-submitted.

A new process has been established so that the criminal record check application process can be completed online at no cost to the volunteer or the association. An email message with details on how to complete the CRC process will be delivered by the NWBA Safety Manager or Registrar. If a cost is levied for any part of the CRC application process, the association will reimburse the amount in full.

COACHING QUALIFICATIONS

NWBA seeks to ensure that we provide a high level of coaching for our players. To this end, NWBA recommends NCCP (National Coaching Certification Program) certification for all of its coaches. Information about the coaching clinics can be found on the Baseball BC website or you can contact our Coach Development Coordinator. NWBA will reimburse coaches 100% of the fees, once they have completed their coaching clinic. Each coach should also complete the Safe Sport training module to ensure the protection of all our athletes. (<https://safesport.coach.ca/participants-training>)

COACH CONDUCT

One of the goals of NWBA is to provide the game of baseball with proper safeguards in place to emulate the spirit of true sportsmanship. Participants are encouraged to get involved by shouting only positive comments (ie. "good swing", "nice try", "good effort", etc.). The following behavior has been noted as unacceptable:

1. No parents or spectators are allowed on the field or in the dugout
2. Use or display of alcohol, tobacco products, vaping or illicit drugs is prohibited during games or practices. **NOTE:** All games are played in public areas under the temporary use by the association, and subject to all laws regarding possession or consumption of alcohol and drugs.
3. Profanity of any kind is prohibited.
4. Unsportsmanlike conduct on the part of the player, coaches, or spectators will not be tolerated. Coaches are responsible for the behavior of his/her team's fans. If a coach cannot control a fan, a Board Member should be notified immediately.
 - a. Making negative comments (ie. "this batter can't hit", that pitcher can't pitch",

etc.).

b. Verbal abuse by any participant (including spectators) towards anybody on the field is not permitted.

NOTE: Only one team warning is given. If the coach / player / parent / spectator continues, the verbal abuse will result in forfeiture of the game for the offending team. Coaches are required to report any incidents to the Division Manager. If the participant continues the abuse after the game or during any other game, a complaint must be forwarded to the President for disciplinary action.

5. Coaches that are ejected from a game are subject to the following disciplinary actions:

- *First Offense* – Suspended from the next game
- *Second Offense* – Suspension for the remainder of the season
- *Third Offense* - Permanent suspension from NWBA

If a coach is ejected two times during the season, they will no longer be eligible to coach with NWBA.

- Ejected coaches must leave the dugout and the field area immediately upon ejection. They may continue to watch the game as a spectator from a distance, however, they may not interact whatsoever with coaches, players or umpires. This will result in a game forfeit.
- Any suspension may be appealed to the NWBA board for review.

During the season, any individual who conducts themselves in a manner which is inconsistent with the goals outlined above, and in doing so, may violate the rights of others who expect the association to protect their rights. The executive is charged with ensuring that the goals of NWBA are achieved. If necessary, disciplinary action may be taken against individuals who conduct is inconsistent with the associations Constitution and these policies herein. For the purposes of this policy, the term "participants" refers to all directors, coaches, players, umpires, parents, and spectators involved in any NWBA activities.

Prior to the beginning of each season, coaches are asked to distribute and collect completed Code of Conduct forms. The forms must be signed by a parent/guardian of the athlete. The coach is required to keep the Code of Conduct Forms throughout the season.

COMPLAINTS ABOUT CONDUCT

To help resolve a situation as quickly as possible, participants of NWBA activities that have a concern or complaint regarding the conduct of any other participant must use the following hierarchy to communicate their concerns.

1. Any Coach on the team. If one of the coaches is the complaint focus, then the Team Parent or Division Coordinator should be notified.

2. The Team Manager or Head Coach of the team or Division Coordinator, either verbally or in writing.

3. The President of the association, in writing/email only. The written complaint will be reviewed by either the President only or by an ad-hoc executive committee review panel.

Participants who wish to appeal a decision that was made at one level of the preceding hierarchy must submit the appeal in writing to the next level in the hierarchy.

Disagreement with the conclusions reached by the President of the association or by an ad-hoc executive committee review panel will not be considered as sufficient justification for any participant to prolong the appeal process.

COACH'S CONDUCT

In addition to adhering to all NWBA policies, coaches are expected to assist in achieving the goal mentioned above as it pertains to sportsmanship, safety, and providing an opportunity for players to play softball. Coaches are expected to put aside their personal objectives and maintain the objective of providing opportunities for minor players to play the game and to improve their playing skills.

Coaches are expected to maintain the proper conduct of players, parents, team spectators and themselves. Difficulties with a player or parent should be discussed with the player and / or parent and brought as a complaint to the manager if a recurring problem is not met with resolution. Coaches should be aware that the directors are available to support them and are willing to oversee their activities on behalf of the association if required. Coaches are expected to remain at the field until all players have left the park.

PLAYER'S CONDUCT

Players are expected to conduct their activities in a safe and sportsmanlike manner. Baseball is a team sport and players have many responsibilities and obligations, towards their coaches and teammates, as they have individual rights themselves. If the friends or relatives of a player attend NWBA activities as spectators, the players should encourage proper conduct from those spectators. By supporting a teammate and encouraging positive reinforcement of behavior, players can set an example that all spectators and adults can model their conduct after.

Players are not to willfully abuse the equipment or uniforms provided for their use by the association. Players should assist the coach by returning all equipment to the designated location when they have finished using it. Parents are expected to ensure that the uniform that has been supplied is maintained in the best possible condition and then cleaned and returned to the coach at the end of the season.

Coaches will inform players as to how and when to notify them regarding absences from practices or games, and players are expected to extend their coach the courtesy of the prior notification. All players are expected to remain in or near the dugout area when they are not on the playing field.

RULE OF TWO

Implementing the 'Rule of Two' means that any one-on-one interaction between a coach and an athlete, both on and off of the field of play, must take place within earshot and view of the second coach, or parent, with the exception of medical emergencies.

PARENT'S / SPECTATOR'S CONDUCT

In addition to the requirements of all participants, parents are also expected to set a positive example to the minor participants and assist the rest of the volunteers in accomplishing the aforementioned goal. For safety reasons, any player in the tball level must have a responsible adult in attendance at all games and practices.

Parents are encouraged to provide assistance to the volunteer coaches, who like all parents, also have other things going on in their lives and are very busy, and yet, have offered some of their valuable time to help someone else's child.

Parents are also expected to assist the coaches in maintaining the proper conduct of their children. Players (or parents) are expected to notify coaches if they will not be attending a practice or game.

Parents and spectators are asked to provide positive feedback and encouragement to all players on the field, or to refrain from commenting altogether. Parents and spectators alike should be cautioned that enforcement of the NWBA policy regarding abuse may result in cancellation of a child's participation in NWBA activities if that is the only way to ensure that an individual will not be present at future games.

SAFETY & EMERGENCIES

We want to emphasize the importance of preventing or effectively dealing with medical emergencies at all our facilities. Realizing we may not be empowered or trained to "treat" victims, we still have the responsibility to render front line aid and supervise the situation. This may involve discussing the situation with the victim, coach, or parent, or to call in the Ambulance Service. In the event that an accident takes place, please be sure to report the incident to the President of the association and complete the necessary accident form and insurance documentation provided by Baseball BC.

The following steps can be performed to help minimize the potential safety risks / hazards that could cause harm to players and/or participants to our sporting activities.

- Prepare an Emergency Action Plan for any location that you may play at

Practice and game safety checklist

1. o Walk the field/inspect dugouts for debris / foreign objects
2. o Inspect helmets, bat, and catcher's gear
3. o Make sure First Aid kit is available
4. o Check conditions of fences, backstops, and bases
5. o Ensure players are warmed up and all are throwing in the same direction

MEDICAL

- o First-aid kits are made available to each team and should be in the equipment bag at all times.
- o Ensure ice packs are replenished as necessary
- o Ensure there is a working cell phone in the event emergency personnel (911) needs to be contacted

PROTECTIVE EQUIPMENT

- o Equipment should be inspected regularly, especially for cracked or damaged helmets.
- o Batters must wear approved helmets during batting practice as well as games.
- o Catchers must wear a long chest protector, shin guards, and a catcher's helmet and mask with dangling throat guard. Hockey style helmets include mask and have a built in throat guard.

- o Dugout / Bench Safety – One adult must be in dugout at ALL TIMES
- o Representatives from teams scheduled for practice or game shall inspect the entire playing field to ensure it is free of debris and hazards
- o Inspect all bases to ensure they are secure and pose no hazard
- o If either coach or game coordinator can't conclude that the field is safe for play, the field shall not be used and the practice or game shall be canceled.

EMERGENCY PROCEDURE GUIDELINES

In the event of an accident or emergency, try to follow the guidelines below:

1. Try to determine the extent of the injury. If in doubt as to the seriousness of the accident, do not move the patient. Keep them comfortable and reassured and call an ambulance. If the situation calls for it, apply ice or keep the patient warm and comfortable.
2. Front line care of an accident would include use of ice, stoppage of bleeding, restoring breathing, and treatment for shock, heat exhaustion or stroke.

3. Be sure the victim is as comfortable as possible. If it's cold, cover them. If it's hot, loosen equipment, etc. USE GOOD COMMON SENSE!
4. Call for additional support. Use other adults to secure necessary materials and never leave the patient alone with other players.
5. If an ambulance is called, be sure you have someone to direct it to the site. Assist paramedics in any way you can.
6. Always prepare an accident report that will be turned in to the NWBA Board member who will then provide the information to Baseball BC and/or the New Westminister Parks & Recreation Department.
7. Be sure you have access to a phone within a short period of time.
8. Call to find out the extent of the injury and how they are doing.

- ★ Coaches need to be aware of the importance of being sure all aspects of an accident are handled properly and expeditiously.

Safe Sport Overview for All Coaches and Participants:

New Westminister Baseball Association Commitment:

NWBA is committed to practicing Safe Sport and ensuring all participants are provided with safe, welcoming, and accessible sport environments, free from all forms of maltreatment. We follow the provincial organizations mandates for all our constituents.

- ★ NWBA and Baseball BC believe that everyone in the sport has the right to enjoy the sport at whatever level or position they participate. Athletes, coaches, officials, and volunteers have the right to participate in a safe and inclusive training environment that is free of abuse, harassment, and discrimination.
- ★ NWBA and Baseball BC believe the welfare of everyone involved in the sport is the foremost consideration and in particular, the protection of children/athletes in the sport is the responsibility of each individual, member, and special interest group in the baseball community. We are committed to being a leader in providing safe, healthy, and inclusive environments for all participants, at all levels of the game.

- <https://www.baseball.bc.ca/safe-sport>

★ **COACHING RESOURCES:**

We have many resources for first time and experienced coaches alike. See links below and you can also contact our Player/Coach Development Officer.

★ **Game Day Guidelines**

- Examples for Tball, Minor, and Major are given during the Coaches Meeting before the beginning of each Spring. These guidelines should be emphasized during all practices and games. Some guidelines may be modified for tournament/crossover play throughout the season.
- [Tee Ball 10 Week Coaching Program - pdf link](#)
- [Coach/Machine Pitch \(Rookie\) Program - pdf link](#)
- **Baseball Canada Rally Cap Program for Tball, Rookies, and Minors:**
 - <https://www.baseball.ca/rally-cap-initiation-program>
- **Baseball BC Coaching Resources -**
 - <https://www.baseball.bc.ca/parent-leader-coaching-program>
- **Little League Practice Plans and Drills:**
 - <https://www.littleleague.ca/Default.aspx?tabid=599744>

★ Baseball Canada Drills and Resources for Specific Positions and Situations for Major Division

Hitting Drills	Pitching Drills	Fielding drills
Load, Stride and Foot Plant	Band (BC)	Bad hop (BC)
Compact Swing	Pre-game prep (BC)	4-6-3 Double Play
Extension and Finish	Towel (BC)	
Raising back elbow (BC)	Pitching Mechanics (Baseball Canada)	Rundown Drill (BC)
Position in batter's box (BC)	1) Breaking down the set motion	Rundown (BC)
Barry Larkin (BC)	2) Leg Elevation	
Inside/Outside	3) Stride, Landing and Power	Outfield drills

Two-ball toss (BC)	4) Shoulder above knee / glove tuck	Rectangle (BC)
Bunting Drills		Safety Catch (BC)
Bunting	Fastball and Change-up Change-up (BC)	Do-or-die
Drag Bunt (BC)	Curveball and Slider Curveball (BC)	Playing the fence (BC)
Catcher Drills	Catcher play throwing	Catcher Drill #1 (BC)
Catcher stance	Catcher play blocking	Catcher Drill #2 (BC)
Catcher play receiving	Catcher throwing to 3rd base (BC)	Catcher Drill #3 (BC)

★ [YouTube Link](#) – Basic Cutoffs and Relays in Baseball

○ First fielder to ball □ Cut-off man △ Call man -----> Ball flight ———> Run path

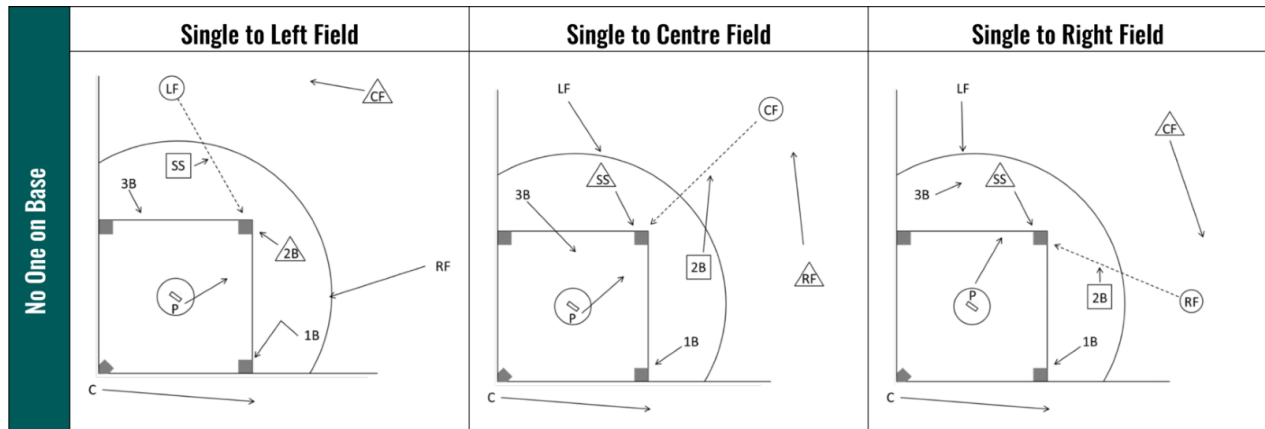

○ First fielder to ball □ Cut-off man △ Call man -----> Ball flight ———> Run path

Runner on First

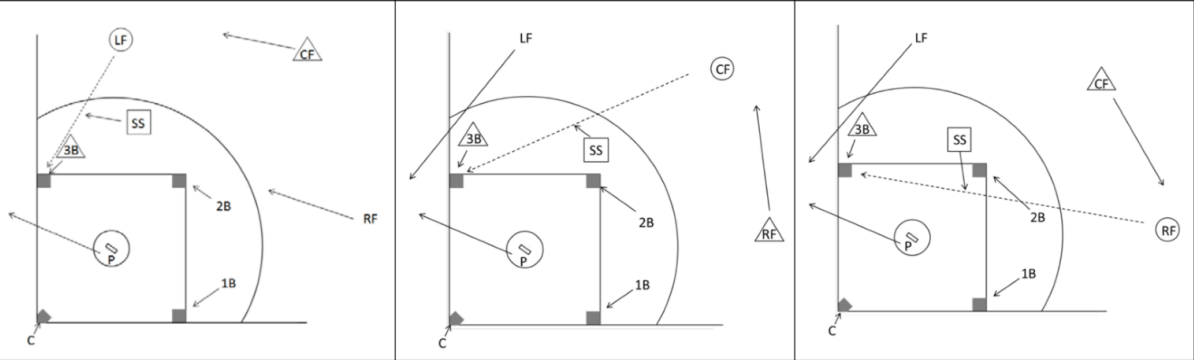

Page Break

○ First fielder to ball □ Cut-off man △ Call man -----> Ball flight -----> Run path

Runner on Second

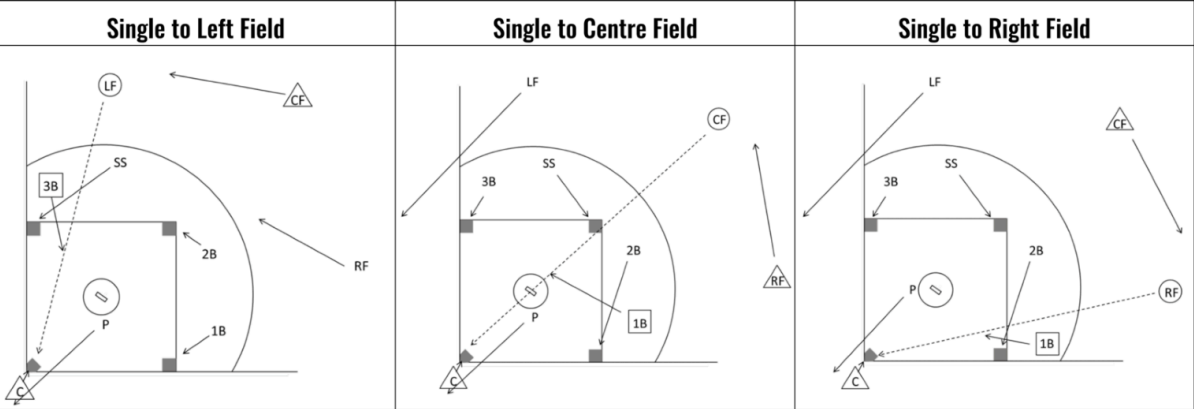

○ First fielder to ball □ Cut-off man △ Call man -----> Ball flight -----> Run path

Runners on First and Second

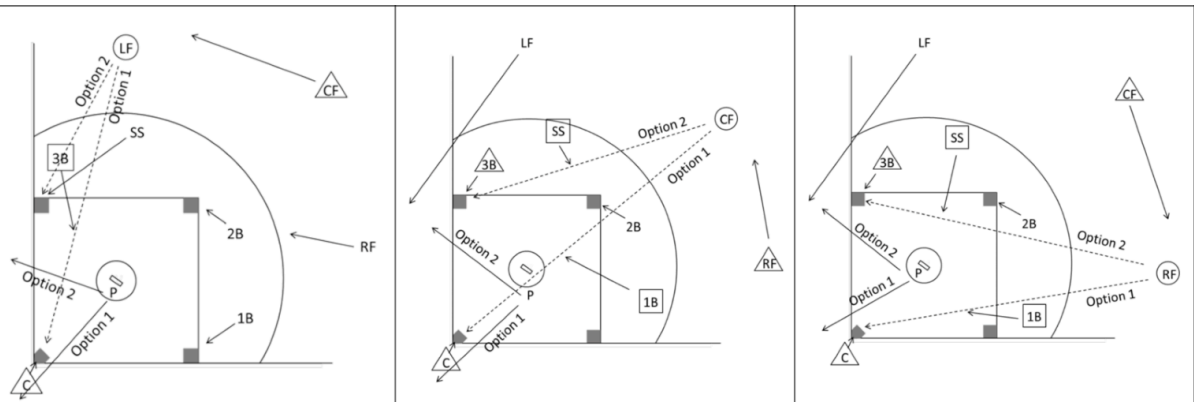

Page Break

○ First fielder to ball □ Cut-off man △ Call man -----> Ball flight ———> Run path

